

1983 Series Pump with Swivel Handle... Parts List, Assemble and Service

October, 2010

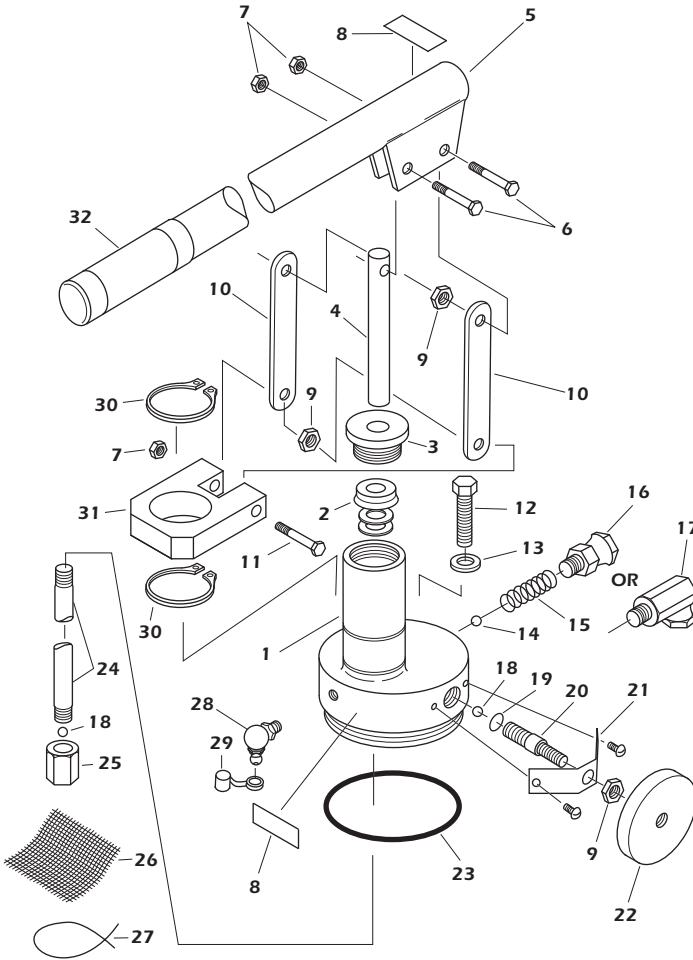

Ref. No.	Part No.	Description
1.	P-BTTJ	Pump Body
2.	HSS-100B	Hydraulic Seal Set (Seal & 2 washers)
3.	9815	Pump Packing Nut
4.	P-5	Pump Piston
5.	PP-D	Pump Handle
6.	6225	Special Handle Bolt (2 per pump)
7.	6020	Nut (3 per pump)
8.	8052	Blue Cap Sticker (2 per pump)
9.	6027	Jam Nut (3 per pump)
10.	P-8	Handle Link (2 per pump)
11.	6220	Special Link Bolt
12.	6260	Pump Retaining Bolt (all-threaded)
13.	6615	Brass Flat Washer
14.	5915	5/16" Exhaust Ball Bearing
15.	5935	Exhaust Spring
16.	5630	Straight Swivel Fitting
17.	5640	90 Degree Swivel Fitting
18.	5910	1/4" Ball Bearing (2 per pump)
19.	5220	Release Valve O-Ring
20.	9820	Release Valve Stern
21.	P-RRA	Release Retainer & Screws
22.	9825	Release Knob
23.	5240	Reservoir Sealing O-Ring
24.	P-(+length)	Intake Tube
25.	9835	Intake Valve Body
26.	IS-250	Intake Screen
27.	P-19	Intake Screen Tie Wire
28.	P-13	Reservoir Air Breather Fitting
29.	5920	Blue Breather Cap
30.	6720	1.25 Snap Ring (2 per pump)
31.	9840	Handle Link Anchor
32.	7880	1" Black Grip

K-series Repair Kits include: #2, #3, #4, #6 (2), #7 (3), #11, #13, #14, #15, #18 (2), #19, #23.

Pump Seal Installation

- Put the #2 thicker I4 gauge Spacing Washer into the #1 Pump Body seal chamber.
- Carefully insert the #2 Poly-Pak Seal into the Pump chamber on about a 20 to 30-degree angle with the Seal's lip going in first. The lowest portion of the Seal should touch or almost touch the Spacing Washer.
- Using a dull 3/16" (4 to 5mm) slotted screwdriver... go around the outside edge of the Seal while forcing slightly inward with the screwdriver and downward with one's fingertip. Make sure the Pump chamber's threads don't cut the Seal's lip. Keep working the screwdriver around the Seal until its bottom is firmly down against the Spacing Washer.
- Screw in the #3 Packing Nut until it bottoms out against the Pump chamber.
- Use the little wire gauge from the Kit to check for a proper gap between the bottom of the Packing Nut

and the top of the Seal. The gap must be at least the thickness of the wire, but never to where the wire can move up and down more than 1/16" (1.5mm).

- If necessary... use any Spacing Washer combination to achieve a proper gap, but never remove all the Washers.
 - All Spacing Washers must be below the Seal.
- If one has access to a product like the blue medium strength Loctite 242 Threadlocker...
 - Unscrew the Packing Nut, wipe its threads clean, put it on its side, and then apply 1 to 1-1/2 drops of Loctite about halfway up the threads.
 - After waiting about two minutes, screw the Packing Nut back into the Pump chamber all the way.
 - Put a little oil on the tip of the #4 Pump Piston and insert it into the Packing Nut and past the Seal with a gentle downward twisting action.

Pump Field Valve Maintenance

Hydraulic Pump Valve Problem: The Meyer Hydraulics' Jack is in contact with the load, but will not raise it... or the load slowly comes down when we quit stroking the #5 Pump Handle. There's no visible external leak of hydraulic fluid under the Cylinder/Hose Assembly or in the connecting #16 or #17 Swivel Fitting.

Initial Checks:

- Make sure the #29 Blue Breather Cap isn't covering the #28 Reservoir Air Breather Fitting (if your Pump has this air breather system). Never put grease in this fitting.
- Check the oil level in the reservoir with the Jack in an upright, fully collapsed or lowered position.
 - If oil runs out the filler hole when you remove the bolt... let the excess oil drain out.
 - Put Hydraulic Jack Oil or MIL-H-5606 Hydraulic Fluid into the reservoir if the level is more than 1/8" (3.2mm) below the filler hole.

Exhaust Valve Malfunction: The Jack lifts the load as we stroke the #5 Pump Handle down, but when we remove our hand from the Handle... the Handle goes up on its own as the load lowers the distance it was raised on the last downward Pump Handle stroke:

- If this condition doesn't apply, go to the Release Valve Malfunction below.
- Open the Release Valve Assembly (#19 to #22) about one full turn. Vigorously jack the #5 Pump Handle up and down about eight times... with a full stroke each time. This should flush any foreign matter stuck between the #14 Exhaust Ball Bearing and its valve seat.
- In the rare case that this doesn't solve the Exhaust Valve malfunction, then do the following procedures:
 - Fully collapse, or lower the Jack to its lowest position. Then carefully disconnect the Hose from the #17 Swivel Fitting, and cap the Hose so oil doesn't run out.
 - Remembering the direction the Swivel Fitting is pointing, remove the Fitting. Now... carefully extract the #15 Exhaust Spring and the #14 5/16" (8mm) Ball Bearing.
 - Visually inspect the valve seat and remove any foreign matter. There should be no need to re-form the valve seat.
 - Put the Ball Bearing and then the Spring back into the Exhaust Valve port. Screw in the Swivel Fitting to where it's as tight as it was before its removal and pointing in the original direction. Re-connect the Hose to the Swivel Fitting without over-tightening. Over-tightening can damage the Fitting's flare.
- The Exhaust Valve malfunction should now be solved.
 - If air has got into the lifting Cylinder/Hose Assembly for the A4xx series, C-1, C-2, DT-2, FL-1, JC, MAC or SRC... then follow the air bleeding instructions found on our Customer Support page (<http://www.meyerhydraulics.com/support.php>).

Release Valve Malfunction: If the Initial Checks above have been done and the Exhaust Valve Malfunction condition doesn't apply, then...

- Lower the Jack completely... and carefully remove the Release Valve Assembly (#19 to #22) and the #18 1/4" (6.35mm) Ball Bearing. Visually inspect the valve seat and remove any foreign matter.
- Replace the Ball Bearing with one that is 5/16" (8mm)... and put it into the Release Valve port. Push the new Ball Bearing completely into the port with a non-hardened 3/8" (9 to 10mm) soft grade #2 or #5 steel bolt.
- Hit the bolt head twice with a 12 to 16oz (340 to 450 gram) hammer with about as much striking force that someone would normally use to hit a common roofing nail. Be careful not to strike the bolt too hard or soft.
- Remove the bolt and Ball Bearing and visually inspect the new valve seat. It should be fully around the small porthole... nice and smooth... and about 1/16" to 3/32" (1.5 to 2mm) wide.
- Put the new ball bearing back into the Release Valve port... and reassemble the Release Valve Assembly into the #1 Pump Body. Tighten the Assembly against the new Ball Bearing by applying moderate torque.
- The Release Valve malfunction should now be solved.

The Hydraulic Pump valve malfunction mentioned in the beginning still hasn't been solved...

- It is therefore suggested that the Hose be disconnected from the Pump Assembly's Swivel Fitting (#16 or #17). Cap the Hose end with a cap so air doesn't get into the Cylinder Assembly.
- Lift the Pump Assembly from the Jack's oil reservoir by unscrewing the #12 Pump Retaining Bolt.
- Return the Pump Assembly to Meyer Hydraulics for a thorough factory inspection, correction and testing.
 - Please include your name, address, phone number, fax number and your email address if possible.
 - Also include the Jack's model, serial number, when the Jack was purchased and a description of the problem you've been having.
- We will contact you concerning any potential charges for repairing any Pump Assembly that's past our normal one-year limited warranty for our lifting equipment.
- A new one-year limited warranty will apply to the repaired Pump.