

# MODEL FL-1 FORK LIFT

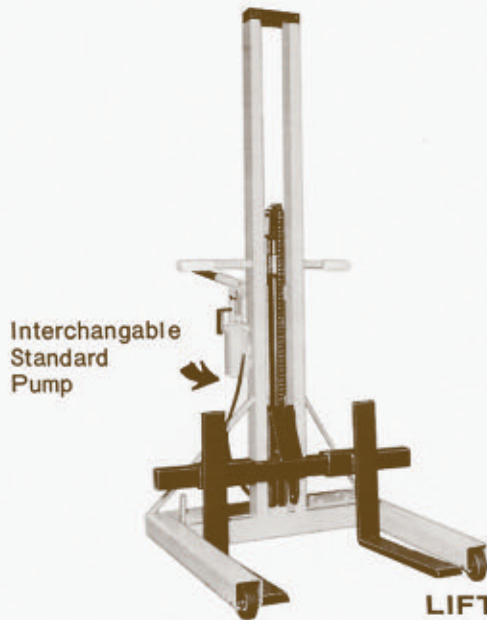
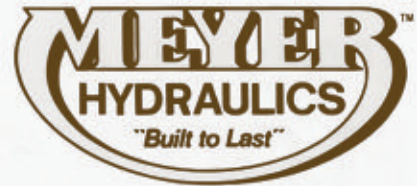

## SPECIFICATIONS

Capacity (at Middle of Forks)	1000 lbs.
Height	71 in.
Length	36 in.
Inside Leg Width	24½ in.
Outside Leg Width	30½ in.
Low Forks	¾ in.
High Forks	50 in.
Forks Adjust from	-9 in. to 58 in.
Wheels (Steel)	4 in.
	(Castors and Fixed)
Forks Made Like Large Fork Truck's - 24 in. long!	

LIFT BARRELS, BOXES, CARTONS, ETC.

## 360 DEGREE ROTATING TABLE

### SPECIFICATIONS

Capacity	2000 lbs.
Low Table Height	30 in.
High Table Height	48 in.
Table Size	24 x 24 in.
All Wheels	
Swivel Castors (Steel)	4 in.

LIFT MANY KINDS OF LOADS EASILY WITH A ONE TON MODEL DT-2!

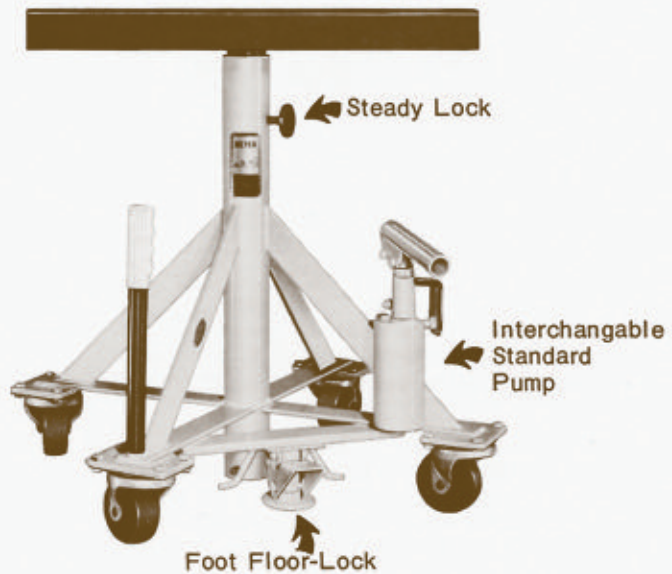

# MODEL DT-2 DIE TABLE



MEYER HYDRAULICS CORPORATION  
CENTREVILLE, MI 49032  
616/467-6302

