

MODELS C-1, C-2, C-4 AND C-6A FLOOR CRANES

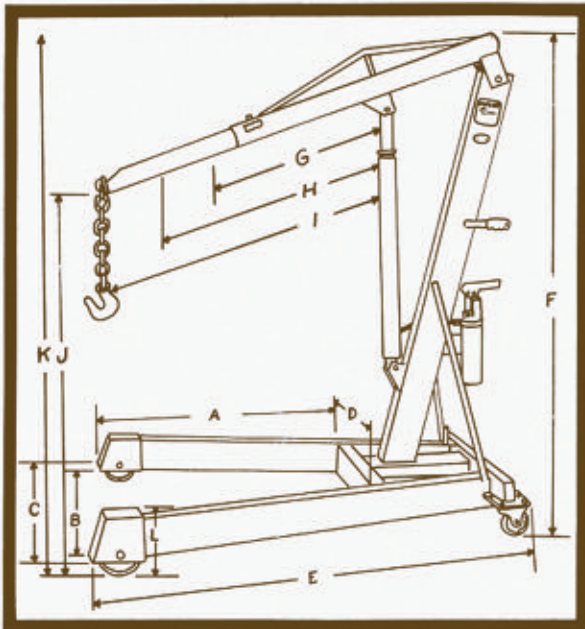

SPECIFICATIONS -

	C-1	C-2	C-4	C-6A
A -	43"	43"	43"	61"
B -	39"	39"	39"	45"
C -	46"	46"	46"	52"
D -	26.5"	26.5"	26.5"	26.5"
E -	63"	63"	64"	82"
F -	72"	72"	74"	74"
G -	26.5"	26.5"	26.5"	44.5"
H -	34.5"	34.5"	34.5"	52.5"
I -	42.5"	42.5"	42.5"	60.5"
J -	30"	30"	30"	20"
K -	120"	120"	120"	130"
L -	5.25"	5.25"	7.5"	7.5"

Front Wheels: C-1 & C-2—4" Steel
 Front Wheels: C-4, C-6A—6" Steel
 4" Steel Swivel on all models(rear)

CAPACITY	G	H	I
C-1	1000 lbs.	750 lbs.	500 lbs.
C-2	2000 lbs.	1500 lbs.	1000 lbs.
C-4	4000 lbs.	3000 lbs.	2000 lbs.
C-6A	6000 lbs.	4500 lbs.	3000 lbs.

Adjustable Hook and Chain

Interchangeable Standard Pump.

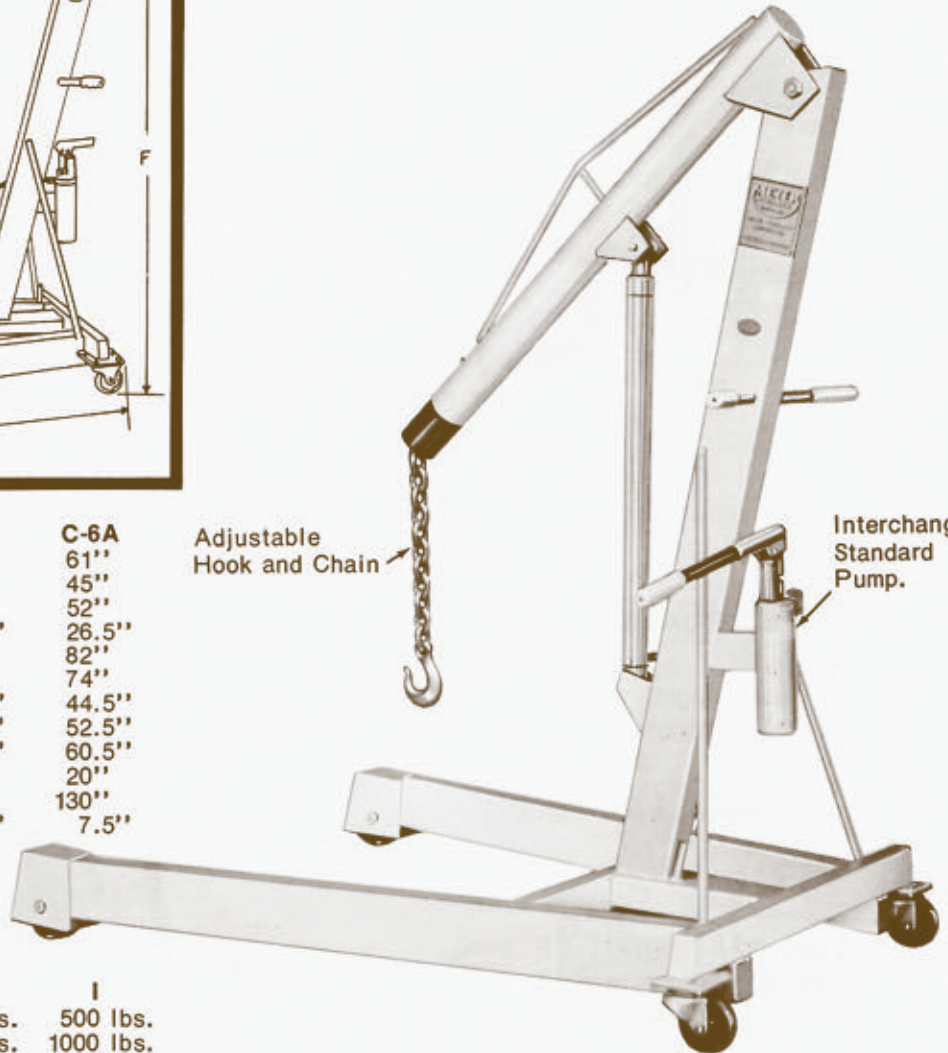

M.H.C. PORTABLE FLOOR CRANES can be used in many different jobs. Built with a stable designed base and easy rolling wheels. These models can save time and energy, while at the same time solve your material handling problems.



MEYER HYDRAULICS CORPORATION
 CENTREVILLE, MI 49032
 616/467-6302

