

Model TJC Multi-Application Crane and Lift System

This is the most adaptable piece of equipment in its field. The over-built TJC can save valuable time and manpower on your unique and often awkward lifting situations.

Long Reach

Up to 64" beyond frame

6,000 lbs. Crane Capacity

3,000 lbs. at full boom extension

Wide Base

46" wide for support and stability (yet fits between dual wheels)

Adjustable Support Legs

Legs extend to 90"

Specifications:

Capacity	14,000lbs
Frame Length w/Extending Legs	58"/90"
Frame Height w/without Boom	78"/62"
Frame Width (inside/outside Legs)	40"/46"
Boom Length from Frame	48"/56"/64"
Boom Capacity: Closed position	6,000 lbs.
Mid position	4,500 lbs.
Extended position	3,000 lbs.
Boom Lifting Range	35" to 130"
Boom Reach Beyond Closed Legs	30"
Lifting Arm Travel (Stroke)	24"
Lifting Pad Range (w/8" adjustment)	14" to 46"
Lifting Pad Slide Adjustment	10" to 43"
Weight	815 lbs.



Removable Boom

14,000 lbs. Jack Capacity

Lifting Pads adjust in two directions

Two 6" H.D. Wheels

Two 6" H.D. Swivel Casters

TJC Lift System Options:

TJC-HB Adjustable High Boom has a lifting range of 14" to 157" and a capacity of 500 lbs. to 1,000 lbs.

TJC-TR Tractor Tire Retainer comes with a crank screw adjustment for tires up to 26 inches wide and 6 feet high

TJC-WD Tire Wheel Dolly Forks have a slide adjustment of 10 to 48 inches. Fork length is 30 inches in front of the lifting arm and lifting capacity is 4,000 lbs. with load centered at 15 inches.

TJC Frame & Boom Specifications...

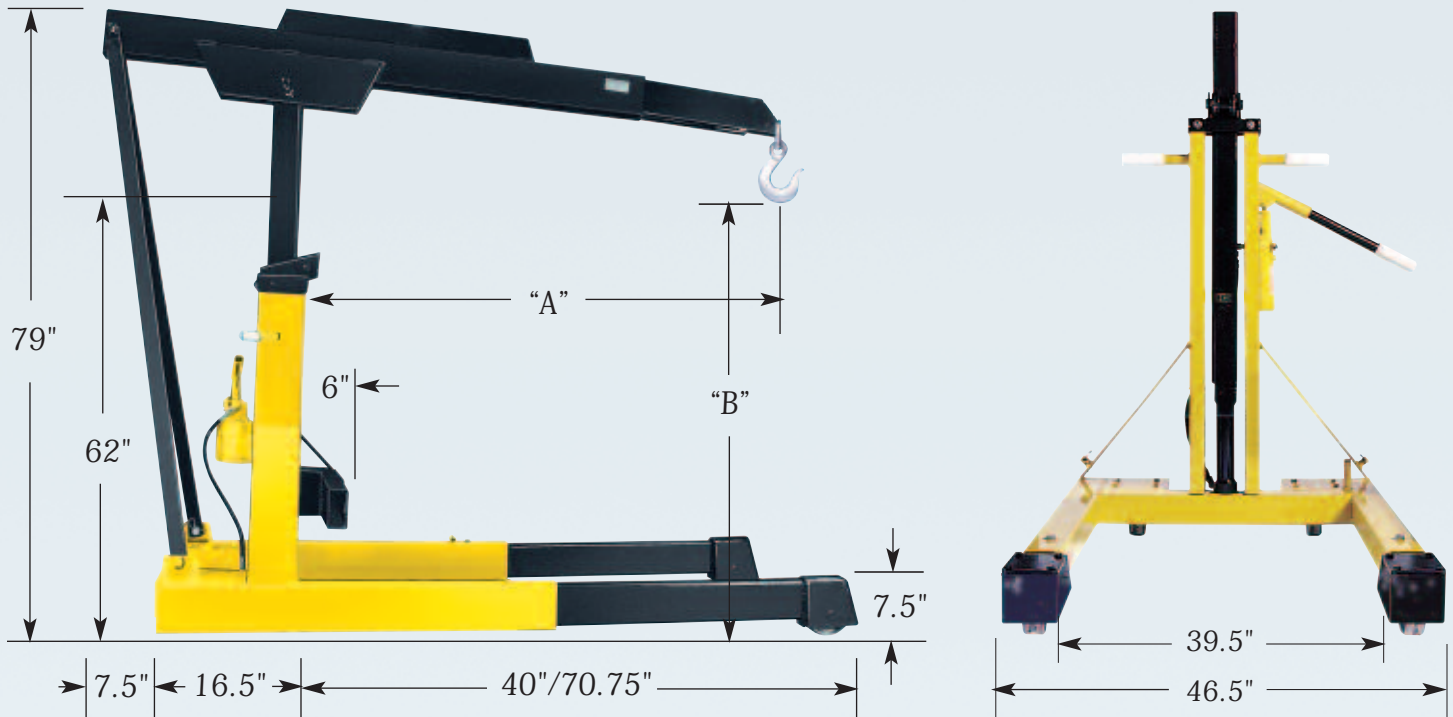

Removable Boom Specifications	Position 1	Position 2	Position 3
Capacity			
Standard Slide Boom			
- with legs extended	6000 lbs	4500 lbs	3000 lbs
- with legs retracted	670 lbs	465 lbs	360 lbs
Optional TJC-HB High Boom			
- with legs extended	1000 lbs	750 lbs	500 lbs
"A" Hook to Frame Distance			
Standard Removable Slide Boom			
Lowered Position (@ -25 degrees)	45.25"	52.5"	59.5"
Horizontal	48.75"	56.75"	64.75"
Mid-Upper Elevation (@ 20 degrees)	44.5"	52"	59.5"
Maximum Elevation (@ 40 degrees)	35"	41"	47.5"
Option TJC-HB High Boom			
Lowered Position (@ -25 degrees)	82.5"	90.5"	98.5"
Horizontal	91"	100"	109"
Mid-Upper Elevation (@ 20 degrees)	84"	92.5"	101"
Maximum Elevation (@ 40 degrees)	67"	74"	81.5"
"B" Floor to Hook Distance			
Standard Removable Slide Boom			
Lowered Position	36"	33"	29"
Horizontal	68"	68"	68"
Mid-Upper Elevation	93.5"	96.5"	99"
Maximum Elevation	117"	122"	126.5"
Option TJC-HB High Boom			
Lowered Position	17.5"	13"	9"
Horizontal	68"	68"	68"
Mid-Upper Elevation	107.5"	110"	113"
Maximum Elevation	143.5"	149"	154.5"

For extra heavy-duty lifting...



End Lift Jack

Even front end jacking is no problem with the TJC Multi-Application Crane and Lift System. The legs can even go between the rear dual wheels, while the lift pads adjust horizontally and vertically.

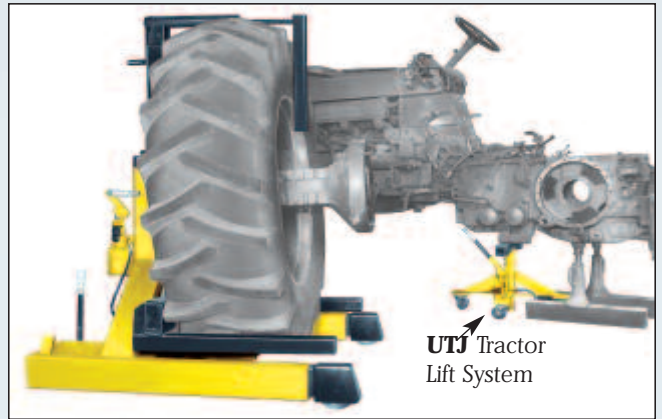

Wheel Dolly

The TJC Multi-Application Crane and Lift System and the Tire Wheel Dolly Forks (TJC-WD) attachment can handle dual wheel assemblies with ease. Add the Tire Retainer (TJC-TR) and you can handle large tractor tires.

Multi-Application Crane...



Engine Lift

Big jobs become easy with the Multi-Application Crane Lift System. The TJC has been designed to handle large, heavy loads with stability, power, and safety.



High Lifting Jobs

Avoid injury during those awkward and dangerous lifting jobs.



Meyer Hydraulics Corporation

512-22 W. Burr Oak Street • Centreville, MI 49032 U.S.A.

800-253-2076 or 269-467-6302

Visit our web site at: www.meyerhydraulics.com

